



# MEDICAL CERTIFICATE

## Personal information

Name \_\_\_\_\_ Personal ID / Motorsport-ID \_\_\_\_\_

Address \_\_\_\_\_

Telephone \_\_\_\_\_ e-mail \_\_\_\_\_

License level    Basic        National        International   

## Medical information

Height \_\_\_\_\_    Weight \_\_\_\_\_    Blood Group \_\_\_\_\_

**Permanent medication** \_\_\_\_\_ ( Yes / No )

**Specify?** \_\_\_\_\_  
\_\_\_\_\_  
\_\_\_\_\_

**Vaccinated against tetanus, when?** \_\_\_\_\_

**Must use glasses while driving** \_\_\_\_\_ ( Yes / No )

### Vision without glasses

Right \_\_\_\_\_ Left \_\_\_\_\_ Comp \_\_\_\_\_

Ishihara \_\_\_\_\_ Normal / Deficient

120 degree vision \_\_\_\_\_ N / D

Central vision without scotoma 20 degrees \_\_\_\_\_ N / D

### Vision with glasses

Right \_\_\_\_\_ Left \_\_\_\_\_ Comp \_\_\_\_\_

Stereoscopic vision \_\_\_\_\_ Normal / Deficient

Nystagmus \_\_\_\_\_ N / D

Romberg standing \_\_\_\_\_ N / D

**Field of vision**

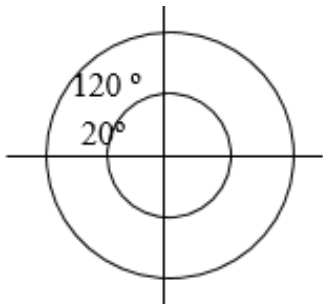

**Draw any insufficiencies**

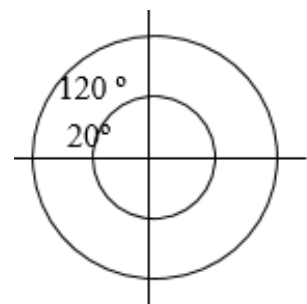

### Cardiovascular aptitude examination

Blood Pressure Done \_\_\_\_\_ (dd.mm.yyyy) \_\_\_\_\_(N/D)  
 Electrocardiogram (ECG) Done \_\_\_\_\_ (dd.mm.yyyy) \_\_\_\_\_(N/D)  
 Exercise Tolerance Test (ETT) Done \_\_\_\_\_ (dd.mm.yyyy) \_\_\_\_\_(N/D)  
 Heart auscultation \_\_\_\_\_(N/D) Lung auscultation \_\_\_\_\_(N/D)

**For all applicants of an International Driver's Licence** blood pressure is taken every year. Applicants of 59 years of age or under, an electrocardiogram is taken in every three years. Result of the electrocardiogram must not be more than 36 months old from the licence application date. From the age of 50 years, a consultation with a cardiologist specialist will be requested in every three years. Applicants of 60 years of age or over at the start of the year of their licence application an electrocardiogram and an exercise tolerance test should have taken place within the previous 12 months. Subsequently, an electrocardiogram should take place every year and an exercise tolerance test and cardiology consultation every two years.

If this doctor deems it useful, depending on the possible symptoms and signs, he/she may ask for further investigations including an exercise tolerance test.

It is recommended for all national licence applicants of 45 years of age or more, to have the exercise tolerance test done at their medical exams to check their medical condition.

### Hearing > 5m

**Right** Normal / Deficient \_\_\_\_\_ **Left** Normal / Deficient \_\_\_\_\_

**Amputated extremities Where?** Draw into picture \_\_\_\_\_ Yes /No

**Impaired functionality or amputation of extremities?** \_\_\_\_\_ Yes/No

Where? Draw into picture

**Functionality of extremities** \_\_\_\_\_ N / D

**Impaired functionality of extremities >50 %** \_\_\_\_\_ Yes /No

**Hand grip strength** \_\_\_\_\_ N / D

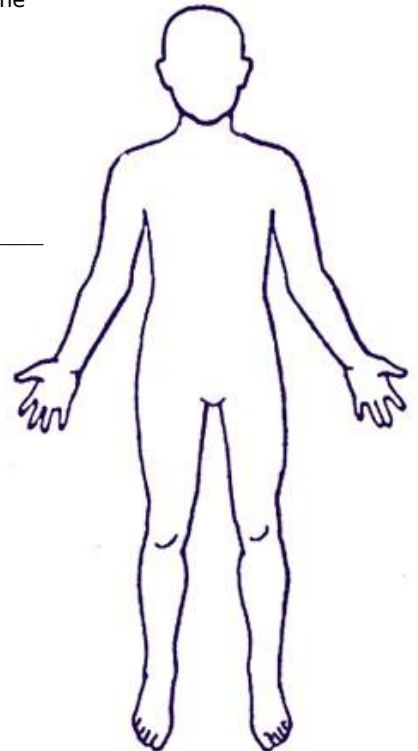

### Physician's signature and approval

It is my opinion that a competition licence can be issued for the examined person

\_\_\_\_\_ ( Yes / No )

**Date and Place:**

**Physician's signature and Doctor ID No. stamp:**

\_\_\_\_\_  
 \_\_\_\_\_

\_\_\_\_\_  
 \_\_\_\_\_

**Delivery:**  
 Secure email [via this link](#)  
 or by mail  
 AKK-Motorsport ry / Lisenssit  
 PL 19, 00130 Vantaa  
 Finland

**NB! The medical certificate is valid for 3 months from the date of physician's signature.**

**Competitor must keep a copy of the certificate!**



## INSTRUCTIONS FOR FILLING AKK-MOTORSPORT MEDICAL CERTIFICATE

There is only one Medical Certificate which must always be used when applying for an International Driver's Licence (and for National Licence, if needed). No other medical certificate may be used except the AKK-Motorsport one. In case of any problems, please contact the national sporting authority and their doctor Mika Pekkonen (mika.pekkonen@autourheilu.fi).

### Cardiovascular aptitude examination

**For all applicants of an International Driver's Licence** blood pressure is taken every year. Applicants of 59 years of age or under, an electrocardiogram is taken in every three years. Result of the electrocardiogram must not be more than 36 months old from the licence application date. From the age of 50 years, a consultation with a cardiologist specialist will be requested in every three years. Applicants of 60 years of age or over at the start of the year of their licence application an electrocardiogram and an exercise tolerance test should have taken place within the previous 12 months. Subsequently, an electrocardiogram should take place every year and an exercise tolerance test and cardiology consultation every two years.

If this doctor deems it useful, depending on the possible symptoms and signs, he/she may ask for further investigations including an exercise tolerance test.

It is recommended for all national licence applicants of 45 years of age or more, to have the exercise tolerance test done at their medical exams to check their medical condition.

If the applicant has been diagnosed for coronary artery disease, the exercise tolerance test must be taken at least every three (3) years. If the applicant has possible coronary symptoms under stress or findings in the exercise tolerance test, no licence may be granted before further examinations by a cardiologist. If the applicant has undergone coronary angioplasty without infarction or in conjunction of one, this is followed by a three (3) month probation period. The exercise tolerance test must be taken before doctor's re-evaluation.

After a bypass operation, there is a six (6) month probation period, provided there are no complications. A stress EKG must be taken before doctor's re-evaluation. In case of applicants who have suffered heart infarction, an ultrasonography should be considered in addition to those mentioned above. The absolute maximum for blood pressure is 160/100 mmHg measured repeatedly. This may be lowered if the applicant has symptoms caused by high blood pressure. A licence may only be issued when the blood pressure has normalised.

### Vision

When applying for an international licence, vision may be evaluated by a general practitioner or optician. Further examinations by an ophthalmologist may be required when necessary. The use of contact lenses is allowed if they have been worn on daily basis for a minimum of 12 months. In addition to that, the lens manufacturer must ensure that the lenses are suitable for automobile sports. Complete blindness of one / both eyes is a contraindication for the use of lenses. An old or congenital visual impairment must be unilateral.

### Following criteria must be fulfilled:

- Visual acuity must be minimum 0.9 in both eyes or 0.8 in the weaker and 1.0 in the stronger eye. If one side is weaker than stated above and correction does not improve vision, total visual acuity must be 1.0 or better.
- Combined static field of vision must be at least 120 degrees, and there may not be scotoma in central field of vision (20 degrees). Perimetry must be carried out.
- Combined field of vision must be functional.
- Normal colour vision, Ishihara.
- If the applicant has a retinal disease, vision must be tested by an ophthalmologist.

If the visual acuity or field of vision of an applicant of an international licence is substantially weakened by an eye disease, there must be waiting period of at least two years before an ophthalmologist can evaluate the level of impairment and function of the eyes. During this period the applicant may not participate in any events. Should one eye go blind, one must wait at least five years before applying for an international licence. Such licence will be then granted by the FIA Medical Commission. For a national licence, we have a one year follow-up period; examination and certificate from an ophthalmologist is required. Decision will be taken by the ASN doctor.

### Mobility of articulations / limbs

The mobility of limbs / articulations must be over 50%. For prosthetic limbs, the functional result must be near to normal. Gripping function must be normal in both hands, amputation of individual finger is not a hindrance.

### Absolute exclusions and special cases

The following illnesses and disabilities may prevent the granting of a licence. For illnesses, a certificate from a specialist doctor in that field or from their own physician is required, together with the decision of ASN doctor.

- Blindness in one eye (ophthalmologist's certificate of stereoscopic vision required)
- Colour blindness (ophthalmologist's certificate required)
- Epilepsy with clinical manifestations, under treatment or not
- Any cardiovascular disease with risk of sudden death (coronary artery disease, high blood pressure)
- Limited functionality of the limbs and disability of 50% or more
- Amputations (except individual finger or toe)
- Difficult senso-motor malfunctions (monoplegia, hemiplegia, paraplegia etc.)
- Diabetes treated with insulin or sulfonylureas
- Any abnormal cardiac or arterial condition, including valvular heart disease
- Any disease of the central nervous system (e.g. Parkinson's, MS disease)
- Psychological conditions (incl. depression)
- Any existing or suspected abnormalities found by the examining doctor

Mika Pekkonen  
ASN Doctor  
AKK-Motorsport